

Installation and Operating Guidelines

SENTRYSUMPSYSTEM™ **and Battery Back-Up Pump System**



Contents

1.0 Product Summary3

2.0 Installation Guidelines3

3.0 Technical Specification.....7

4.0 Dimensions.....7

5.0 Parts List8

6.0 Accessories.....8

7.0 Wiring Diagrams.....9

8.0 Transport10

9.0 Maintenance.....10

10.0 Health and Safety.....11

11.0 Guarantee.....12

12.0 Service Agreement.....12

1.0 Product Summary

The Sentry Sump System™ is specially designed for the removal of groundwater from basement cavity drainage membrane systems. The system comprises of a polyethylene tank, locking access cover and powerful submersible pump. The tank has a number of pre-moulded inlet points for easy installation of the Oldroyd Aquadrain drainage channel.

The system comes complete with a battery back-up pump system, which is designed especially for where the possibility of primary pump failure through either a pump fault or loss of mains power would be catastrophic. The system acts as a back-up that will alert the end user if the water rises above the normal operating level within the tank and will activate a 24V back-up pump. The system is designed to activate via three separate float switches inside the tank that are set to activate higher than the activation point of the primary pump. The panel contains two batteries that are trickle charged that will keep the back-up system operational in situations of mains power failure and/or pump fault (please refer to section 3.2 'Battery Back-Up Pump System' for details of battery life).

2.0 Installation Guidelines

It is important to note that these instructions are for guidance only and it is the contractor's responsibility to satisfy themselves that the installation procedure is in accordance with the site conditions and good building practice, to eliminate any potential damage to the system either during or after installation. The installer should also satisfy themselves that the system can be installed in conjunction with these guidelines, prior to work commencing.

The tank is manufactured from polyethylene and as such is extremely robust. However, as with any preformed tank they are susceptible to floatation and hydrostatic pressures exerted in high water table conditions.

Please read these instructions in full prior to commencement of the installation. If you are unsure on any point then please ask for advice before proceeding. Our technical helpdesk is available on 01442 211554 from 8:30 – 5:30 pm, Monday to Friday.

2.1 Sentry Sump System

1. Select a suitable location for the pumping station. It is extremely important to site the system with permanent access in mind for routine maintenance of the system.
2. In all instances the tank **MUST** be positioned on a flat, level, concrete base of dimensions sufficient to fully support the base of the tank. Simply lay clean hardcore to the base of the excavation ensuring that it is consolidated to a thickness of 100mm, then lay a mass concrete to a thickness adequate for the ground conditions and of minimum 150mm thickness, on top of the hardcore.

Carefully position the tank onto the WET concrete base ensuring that no loose debris is inadvertently knocked onto the base, under the tank during this procedure. Push the tank into the wet concrete by 50mm ensuring that the concrete is fully imbedded into the bottom of the tank. Position it such that the inlet and outlet pipework is correctly aligned.

3. Once the tank is positioned connect the incoming drainage channel. To do this you must select the appropriate recessed channel entry point and open it up by sawing off as little as possible to allow

maximum support for the incoming drainage channel. It is essential to de-burr the edges of the channel entry point for safety reasons.

IMPORTANT – The incoming drainage channel must only be pushed approximately 30mm into the tank so as to not impede with the removal of the pumps for maintenance purposes.

4. We recommend that the discharge pipework is 1¼” solvent welded Class E PVC pressure pipe. To connect the discharge pipework to the discharge spigots on the tank you must firstly screw on the 1¼” Plain/Threaded PVC Sockets (supplied within fittings bag) onto the spigots which will then leave you with two plain sockets to solvent weld your discharge pipework into.

We recommend that two separate discharge lines are installed to increase the flow, should a single discharge line be required a Tee Piece Kit will be required (see section 6.0 Accessories).

Please note that should a single discharge line be used the overall flow will be reduced should the first pump become inundated.

5. It is recommended that 1¼” gate valves (see section 6.0, Accessories) be installed on the discharge lines should the vertical lift exceed 3 metres and/or the discharge line be connected to a foul water outlet.
6. The electrical cables should now be drawn through a cable duct back to the electrical source via the 50mm rubber fitting supplied in the fittings bag. When installing the rubber seal simply select your preferred location within the neck of the tank and drill a hole using a 76mm hole cutter before pushing the rubber seal into place. Once in position run a 50mm pipe from the rubber seal to the electrical source.
7. In all applications the tank must be backfilled with a mass concrete mix of a minimum 100mm thickness and used in accordance with the ground conditions ensuring that it is as dry as practical to prevent additional floatation pressures being exerted on the tank.

The tank **MUST** be ballasted with water at the same rate as backfilling such that the level difference between the water and the backfill does not exceed 150mm at any time.

Please ensure that when pouring the concrete backfill, suitable steps are taken to prevent the concrete from entering the tank and Aquadrain channel.

8. Where groundwater is present in the excavation, local de-watering of the ground must be undertaken throughout the installation procedure until the backfill has fully cured. Please note that the ballast water inside the tank should not be removed until the backfill has fully cured.
9. It is extremely important that once the tank has been installed and all the inlet connections made, before the pumps are installed, the system is flushed through and all sand, silt, rubble and general debris removed from the tank. **FAILURE TO DO THIS WILL INVALIDATE THE WARRANTY ON THE PUMP.**
10. Once the tank is in position and the discharge pipework is in place, you must connect the pumps to the discharge lines. Please ensure that the primary pump is located on the base of the tank with the back-up pump located on the step. You will need to solvent weld the elbow to the vertical discharge pipe located on the primary pump. The 24V pump is to be connected to the discharge pipework via the rubber non-return valve. The 1¼” threaded coupling from the pumps must be screwed onto the

exposed thread of the socket unions, ensuring that the pumps are seated properly with the rubber washers in place. Please ensure that you remove the tape from the tank connectors that hold the rubber washers in place. Lastly the nut located in the primary pump switch needs to be removed to connect the float switch in place. Once connected the nut needs to be screwed back into place.

2.1.1 Electrical Connections

A qualified person in accordance with the Institute of Electrical Engineers Regulations should connect the unit to the mains supply taking into account all the electrical information provided.

1. The primary pump should be connected to a 230V 5A fused spurs by a suitably qualified person in accordance with the institute of Electrical Engineers Regulations.
2. Please ensure that there is suitable slack on the cable to allow for the pump to be removed for maintenance.

2.2 Battery Back-Up Pump System

2.2.1 Electrical Connections

A qualified person in accordance with the Institute of Electrical Engineers Regulations should connect the unit to the mains supply taking into account all the electrical information provided.

1. Select a suitable location for the control panel, taking into account that the panel must be located within 5m of the pump. It is important to bear in mind access to the control panel for maintenance purposes, ensuring it is located in a dry area and the audio alarm is audible to the end user.
2. Mount the panel to a wall or backboard using the mounting points at the back of the panel and appropriate screws and wall plugs (not supplied).
3. The three float switches need to be fixed to the metal bracket using the fittings provided (plastic washer and nut). Place the float switches into position ensuring that the activation arm is down and fixed into position using the plastic washer and nut.

The float switches should be located within the tank ensuring that the following configuration is adhered to:

'Run' Float	Top of bracket
'High Level Alarm' Float	Middle of bracket (float is to be higher than the primary pump float switch).
'Off' Float	Bottom of bracket

4. The electrical/float cables should be drawn through the cable duct back to the control panel, please note that the electrical cable should first go via the 'IP 66 rated junction box (supplied in fittings bag).
5. The panel should be connected to a 230V 13A fused spur by a suitably qualified person in accordance with the institute of Electrical Engineers Regulations.
6. For connection to the mains supply it is imperative that the panel is connected to a separate fused spur to that of the primary pump. This is because should a fault occur with the pump and blow its fuse, then the back-up system can still operate.

7. Please ensure that there is suitable slack on the cable to allow for the pump to be removed for maintenance.
8. To commission the control panel you must connect both the batteries using the connectors provided, a red indicator on the battery charger will inform you that the batteries are now charging, once fully charged the red indicator will turn green. To test the system, disconnect the primary pump from the panel and fill the tank with water until the back-up pump activates. Please note that prior to the back-up pump activating the high level alarm should sound.

2.2.2 Control Panel Operation

The most important element of the battery back-up system is the control panel as it controls and monitors and status of the complete system.

The panel consists of both visual and audio indicators that are imperative for both the installer and end user to fully understand.

Visual Indicators

White Indicator (Supply On)	This indicates whether there is a mains supply connected to the unit. Should the mains supply be removed (i.e. Power failure, blown fuse) the light will go out.
Red Indicator (Fault)	This indicates whether there is a fault with the back-up pump, such as a blockage, blown fuse or that the batteries have run dry.
Green Indicator (Running)	This indicates that the back-up pump is in operation.

Audio Indicators

The battery back-up system comes complete with an audio alarm to alert the user when there is a high level situation within the tank. Also located on the front of the panel is an alarm mute button to silence the alarm in a high level situation.



Internal configuration

3.0 Technical Specifications

3.1 Sentry Sump System

Model	Sentry Sump System
Power Supply	230V AC
Rated Current	3.6A
Motor Rating	800W
Frequency	50Hz
Revolutions Per Min.	2900rpm
Max Vertical Output	12m
Max Horizontal Output	80m
Max Flow Rate	240l/m
Max Liquid Temp.	<50°C
Discharge Size	1¼"
Cable Length	5m
Weight	12Kg
Tank Colour	Blue

3.2 Battery Back-Up Pump System

Model	Battery Back-Up Pump
Power Supply to Panel	230V AC
Power Supply to Pump (via panel)	24V
Frequency	50Hz
Motor Rating	Intermittent
Max. Vertical Output	6.5m
Max. Horizontal Output	45m
Max Flow Rate	180l/m
Max. Liquid Temp.	<40°C
Rated Current	13A
Discharge Size	1¼"
Cable Length	4m
Battery Life	45min

4.0 Dimensions

4.1 Sentry Sump System

Tank Diameter	600mm
Tank Height	600mm

4.2 Battery Back-Up Panel

Height	380mm
Width	300mm
Depth	180mm

5.0 Parts List

5.1 Sentry Sump System

Qty	Product Name
1	Tank
1	Access Cover, Locking, Solid Top
1	Float Bracket
1	Ama-Drainer 303 SE
1	PVC Pipe + Fittings
1	Non-Return Valve
1	50mm Rubber Seal (Cable Duct)

5.2 Battery Back-Up Pump System

Qty	Product Name
3	Mini Float Switch
1	Control Panel
1	Non-return valve (Rubber)
1	24V Back-Up Pump
1	PVC Pipe + Fittings
1	IP 66 Rated Junction Box

6.0 Accessories

Product Name
110mm Rubber Seal (Drainage Inlet)
50mm Rubber Seal (Inlet/Cable Duct)
1¼" Brass Gate Valve
12V, 7Ah Battery
Access Cover, Recessed 450 x 450mm
T-piece kit

7.0 Wiring Diagrams

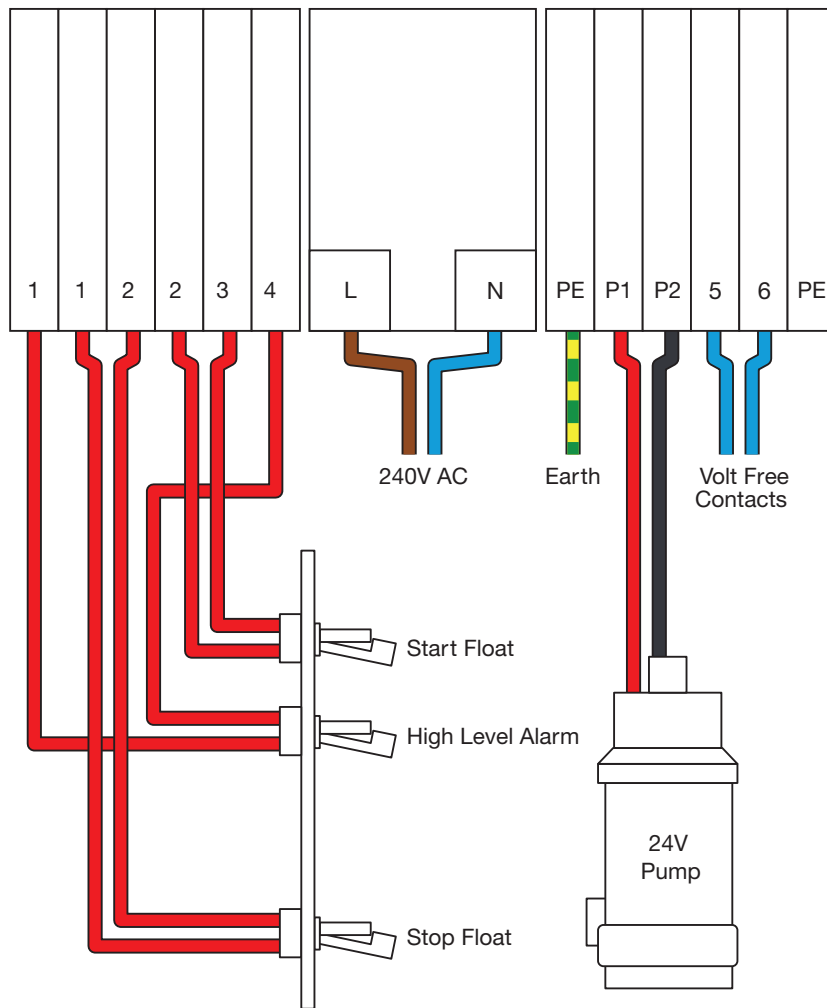

8.0 Transport

The pumps are shipped disconnected from the pipework to avoid damage in transit. Carefully unpack the Sentry Sump System from its packing and inspect for any signs of damage. Should there be any damage present it must be reported immediately (no claim will be considered after 48 hours from time of delivery).

9.0 Maintenance

The Sentry Sump System requires minimal maintenance, however it is strongly recommended that the unit is serviced quarterly during the first year. It is essential that the unit is serviced at least annually thereafter.

To clean out the unit you must first turn off the power supply and ensure that it cannot be inadvertently turned back on (i.e. remove the fuse). Now remove the access cover to gain access to the pumps. Next you must remove the pumps from the tank by disconnecting the pipework and lifting the pumps out. It is advisable to check the underside of the pumps to ensure there is no build up of debris around the pumps and the float switch as this can often lead to poor pump performance or damage to the pump itself. You must also clean out the tank ensuring that there is no debris in the bottom of the tank. Now that the tank is clean you must reconnect the pumps to the pipework and check the function of the pumps prior to replacing the access cover.

It is advised that the operation of the battery back-up system is checked every 6 months; this can be done by removing the power supply to the primary pump and allowing the tank to fill with water until the back-up pump activates. It is also advised that every 6 months the system is allowed to operate using only the back-up pump, this is to allow the batteries to run down and fully recharge which in turn will help to extend the life of the batteries.

Please note that we recommend that the batteries be replaced every 2 years.

In addition we strongly recommend that a service agreement be taken out, please refer to section 12 for further information.

10.0 Health and Safety

Please pay attention to the following regulations when installing the pump system or ask your qualified electrician/distributor.

Safety Precautions

In order to minimise the risk of accidents in connection with the service and installation work, the following rules should be followed.

- Do not ignore health hazards. Observe strict cleanliness.
- Bear in mind the risk of electrical accidents.
- Use a safety helmet, safety goggles and protective shoes.
- All personnel who work with sewage systems must be vaccinated against diseases to which they may be exposed.
- A first aid kit must be close to hand.
- Note that special rules apply to installations in an explosive atmosphere.

Electrical Connections

- The following works should only be done by qualified and authorised electricians.
- Edincare and Safeguard Europe disclaim all responsibility for work done by untrained and/or unauthorised personnel.
- Heed operating voltage (see name plate and additional labels).
- Take out the main fuses to isolate the mains supply from the control unit before repairs or any other works and ensure it cannot be energized again.
- As the pump is equipped with an automatic level control, there is a risk of sudden restart.
- Before starting check the efficiency of the protective arrangements of the pump and the monitoring equipment. Failure to heed this warning may cause a lethal accident.
- Do not put the lead ends into water! Irruption of water may cause malfunctions.
- If persons are likely to come into physical contact with the pump or pumped media, the earthed (grounded) socket must have an additional connection to an earth (ground) fault protection device (GFI).
- Use the pump only in accordance to the data stated on the pump's plate.
- Connection only to a mains supply installed in accordance to the local regulations. For fusing of D.O.L. starting pumps use only appropriate slow fuses or automatic circuit breakers with D characteristics. This is because the motor's nominal voltage is measured at the terminal board of the pump; please consider the voltage drop of long supply cables.
- Replace the cable if the cable jacket is damaged. Do not pinch the cable or pull it around sharp bends.
- Always install the control unit in a dry and well ventilated room. Never install the control unit within the tank.

Earthing

For safety reasons, the earth conductor should be approximately 50mm (2") longer than the phase conductors. If the motor cable is jerked loose by mistake, the earth conductor should be the last conductor to come loose from the first terminal. This applies to both ends of the cable. Ensure the correct earthing of the pump and control unit.

11.0 Guarantee

12 month component Guarantee

If within the guarantee period of a product any defect is discovered in respect of workmanship, construction or material, we will make good the defect or replace the defective part at our expense inside normal working hours at the company's premises providing, written notice is given immediately the defect is discovered and that, if required by us, the part or complete unit is returned to the company's premises carriage paid. Spares or repaired parts are delivered ex works exclusive of fitting. The guarantee does not apply to defects caused by incorrect installation, abnormal conditions of working, accidents, misuse or neglect. Our responsibility is in all cases limited to the cost of making good the defect or replacing the defective part at the company's premises inside normal working hours. We exclude all liability for any consequential or other damage or losses which may occur. We will not be liable if the pumping system fails due to it having been incorrectly specified (e.g. where the pump is inundated due to an inadequate waterproofing design or where the pump is used to discharge inappropriate media).

12.0 Service Agreement

All systems are manufactured to the highest standard and we have every confidence the product will serve you well. However as with most appliances of this nature, regular maintenance is essential in ensuring your system operates at its optimum level and fulfils the expected life span.

Our Service Agreement scheme is available at competitive prices, and we will undertake to service equipment at regular intervals. We will supply you with a full report on the work done and the condition of the pump/s and all related equipment each time our engineers attend site.

You can see significant benefits through:

- Reduced running costs including energy and maintenance
- Greater life expectancy for equipment
- Reduced risk of breakdown with its resultant problems and inconvenience
- Better plant utilisation
- Improved environmental conditions

Our Service Agreements consist of the following:

- Scheduled service visits per year
- Reduced hourly charges for un-scheduled call outs
- Fully trained service engineers

Please find attached the service documentation, comprising of a Service Agreement, Equipment Schedule and Work Schedule. Simply complete the enclosed documentation and return to:

Edincare Pumped Drainage Systems
Unit 8, Heron Business Park,
Eastman Way,
Hemel Hempstead,
Hertfordshire HP2 7FW

Important Information

System Installed:	<input type="text"/>
Name of Purchaser:	<input type="text"/>
Purchased From:	<input type="text"/>
Date of Purchase:	<input type="text"/>
Installation Address:	<input type="text"/>
Installation Date:	<input type="text"/>
Installed By:	<input type="text"/>
Serial Number of Main Pump:	<input type="text"/>
Serial Number of Back-up Pump (if applicable):	<input type="text"/>

Service Log

Date	Procedures Carried Out and Parts Replaced	Signed

Safeguard Europe Limited

Redkirk Close

Horsham

West Sussex RH13 5QL

United Kingdom

Tel: 01403 210204

Fax: 01403 217529

Email: info@safeguardeurope.com

Web: www.safeguardeurope.com



Supplied in conjunction with



SERVICE AGREEMENT FOR UNITED KINGDOM INSTALLATIONS

Customer No. (Office Use Only):

Contract No. (Office Use Only):

An agreement made on (Date):

between (in this agreement referred to as "the Client"):

Name:

Address:

Post Code:

and (in this agreement referred to as "the Company"):

Edincare Pumped Drainage Systems
Unit 8, Heron Business Park,
Eastman Way,
Hemel Hempstead,
Hertfordshire,
HP2 7FW

of which it has been agreed that:

(1) As from the date of signing this agreement, the Company will undertake to service the equipment as recorded under 'Equipment Schedule' at the location recorded under 'Work Schedule'.

(2) **Service Intervals**

The service(s) will be carried out at intervals of (Tick appropriate box)

<input type="checkbox"/> Once per year	<input type="checkbox"/> Twice per year
<input type="checkbox"/> Four times per year	<input type="checkbox"/> Other <input type="text"/>

The number of visits per annum is dependent on equipment and application type. Please contact us for the recommended number of visits per annum.

(3) **Service Charge**

(Tick appropriate box)

<input type="checkbox"/> 2-3 year service agreement (charge per service visit)	£ <input type="text"/> + VAT
<input type="checkbox"/> 4-5 year service agreement (charge per service visit)	£ <input type="text"/> + VAT
<input type="checkbox"/> <input type="text"/> (charge per service visit)	£ <input type="text"/> + VAT

The annual service charge is calculated on the service charge per visit multiplied by the service intervals. The amount above will be paid by the Client to the Company in accordance with Clause 9 of this agreement until further notice as provided for in Clause 4 of this Agreement.

(4) **Duration of Service Agreement**

The duration of the Agreement shall be for a period of years from the date of signing this Agreement ("the term").

Agreement termination date: / /

At the end of the term, the agreement will automatically continue from year to year, unless either one of the parties to this agreement gives 6 months prior written notice to the other before the expiration of the term or, before the end of any subsequent year.

(5) **Site Access**

The Client is responsible for ensuring immediate, safe and uninterrupted access to the pump equipment. The Client will incur additional charges if there has been any interference with the equipment, interrupts the engineer, fails to provide the required access or unreasonably delays the engineer's work.

(6) **Cancelling Service Visits**

The Client must advise the Company of a date change or cancellation no less than 3 working days (Monday-Friday, 8:30am to 5:30pm) before the Service Visit. The full Service Visit charge will be applied for non compliance.

(7) **Insurance**

The Company excludes all liability for any consequential or indirect loss suffered by the Client whether this loss arises from breach of a duty in contract or tort or in any other way (including loss arising from the Company's negligence). Non exhaustive illustrations of consequential or indirect loss include: Loss of profit; Loss of contracts; Damage to the property of the Client or anyone else; Personal injury to the Client or anyone else (when the injury is not caused by the Company's negligence).

(8) **Defects**

This Agreement does not apply to defects caused by incorrect fitting or erection, usage of third party equipment, abnormal conditions of working, accident, misuse, neglect or, interference or attempted repairs or servicing by a third party.

Repair works will not be undertaken prior to the Company receiving an official instruction from the Client to proceed at an agreed price.

(9) **Payment**

The Annual Service charge is to be paid to the Company in full upon the yearly anniversary from the date of "agreement made" during the continuance of the Term. The Company reserves the right to charge interest on overdue amounts at 3% above the Base Rate of Barclays Bank PLC from the time being in force for the period from date payment is due until the actual date of payment. The Company reserves the right to suspend all obligations including service calls under the Agreement if the Annual Fee (or any other invoiced amount payable pursuant to this Agreement) is due, owing and remaining unpaid. Where accounts have been approved for credit, payment terms are 30 days from date of invoice. For all non account customers a proforma invoice will be raised requiring payment in advance of the due date.

(10) **Replacement Components**

This Service Agreement does not include for free replacement or repair of components. However, wherever possible if deemed necessary, any essential service or repair will be effected during a Service Visit and invoiced accordingly. Such decision to be at the sole discretion of the Company to a maximum of £150 + VAT.

Any works required above £150 + VAT will not be undertaken prior to the Company receiving an official instruction from the Client to proceed at an agreed price.

(11) **Price Review**

The Company reserves the right to increase the fee payable under this Agreement by the same percentage as the increase in the Retail Price Index, as published by the relevant Government Department and/or revise the fee payable under this Agreement, such increases/revisions to be notified to the Client prior to the "termination date" in accordance with Clause 4 of the Agreement or, before the end of any subsequent year thereafter.

(12) **Site Report**

A report will be issued relating to the: Operation of the equipment; Condition of the Equipment; Client responsibilities. Any remedial works required and associated charges will be advised.

(13) Removal/Suspension of Service

Without prejudice to any other rights or remedies of the Company: If a receiver or manager is appointed over any of the assets or undertakings of the Client; or a petition is presented for the appointment of an administrator or a winding up petition is presented against the Client; or the Client goes into voluntary liquidation or calls a meeting of or makes any arrangement or composition with its creditors; or the Client commits any act of bankruptcy or becomes unable to meet its debts within the meaning of Section 123 of the Insolvency Act 1986; or there is any default by the Client in making payment according to this Agreement, the Company shall be entitled after having sent written notice requesting payment within seven days to the Client (Which shall be deemed to have been validly given if sent with a Certificate of Posting to the last address known to the Company) – to suspend all services until all monies have been duly received by the Company.

(14) Transfer of Contract

The Client shall not transfer this Agreement, or any part of it, to any third party without the Company's written authorization which, subject to administration fees, shall not be unreasonably withheld. Notwithstanding the transfer of this Agreement, the Client will remain liable under this Agreement but this liability shall cease within six months of the transfer provided that the Client is not in breach of the terms of this Agreement and that at the expiration of the said six months there are no outstanding breaches of the Clients obligations under the terms of this Agreement and the Company is satisfied that the party to whom this Agreement is to be transferred has agreed in writing with the Company (to the Company's satisfaction) to be bound by the terms of this Agreement and is likely to comply with such terms.

(15) Contract Modification

The terms and conditions of this Agreement supersede any terms or conditions proposed by the Client and may not be varied except with the written consent of a Director of the Company. In the case of a written consent by a Director of the Company to a variation or deviation from one

or more of the terms and conditions of this Agreement, the other terms and conditions shall remain fully operative.

(16) Early Termination by the Client

The Client may terminate this Agreement by giving not less than 6 or more than 7 months prior notice in writing to the Company ("Notice to Terminate") such notice is to be sent by registered post to the registered office of the Company together with all monies then due to the Company up to the date of the Notice to Terminate. Upon the expiration of the period referred to in the Notice to Terminate (but subject to the provisions set out below) this Agreement will terminate (the "Termination Date"). The Company will within 1 month of receipt of the Termination Date provide the Client with a calculation of the sums due under this Agreement which sums will be payable on the Termination Date and will be calculated as follows:

(a) all monies then due

(b) a capital sum equal to the total of the Service Charges payable under this Agreement for the remainder of the Term (based on the prevailing Services Charges at the time this Agreement is terminated). In the event that the procedure that the Client is required to follow as set out above is not strictly followed or the Client is in breach of any of its obligations referred to in this Agreement at the time of service or during or at the end of the notice period referred to in the Notice to Terminate then the Notice to Terminate may (should the Company so wish) be treated as invalid and will have no effect. For the avoidance of doubt the fact that Notice to Terminate has been served will not release or vary the Client's obligations under this Agreement including (without prejudice to the above) the obligation to pay the Annual Service Charge or any other payment due. Time will be of the essence in relation to the time for service of the Notice to Terminate.

(17) Overseas Purchases

This Agreement is not available where the product is sold or installed outside of mainland UK.

On Behalf of The Client:

Customer name (Print):

Customer Signature:

Position:

Date:

On Behalf of The Company:

Company name:

EDINCARE PUMPED DRAINAGE SYSTEMS

Directors Signature:

Date:

I, the above, acknowledge receipt of this Service agreement. I have read and understood its contents and agree to abide by the terms and conditions therein.

Customer No. (Office Use Only):

Site address (if different from above):

Name:
Address:

Post Code:

Site contact:

Telephone (Home):

Telephone (Work):

Mobile:

Fax:

Email:

Location of installation:

(Back Garden near shed. Please provide details of installation e.g. internal or external, brief description of where on the above property the unit is installed.)

Preferred service month(s):

Jan Feb Mar Apr May Jun
Jul Aug Sep Oct Nov Dec

Notes

EMERGENCY CALL OUT

'All emergency callout visits will be charged at our 'Emergency Call Out – Service Agreement' tariff. For hourly rates and full terms & conditions please refer to our 'Service Request Form' (available upon request).

WORK SCHEDULE (TO BE PERFORMED AT EACH VISIT)
Condition on Arrival
Pump/s Running
High Level Alarm
Pump Tripped / Overload
Condition of Pump (Visual Inspection)
Clear & Free
Blocked
Condition of Pump (Mechanical Inspection)
Impeller
Bottom Plate
Cutters
Condition of Oil
Manual Impeller turn
Bearing Side movement
Control Panel
Overload Setting
Operation of Float Switches
Bulbs / Fuses
Alarm Mute Function
Running Current
General
Pedestal / Guide Rail
Debris
Float Switches / Level Controls
Valves / Pipes
Access Cover
Chamber/Tank
Lifting Chains

EQUIPMENT SCHEDULE	
Product Name:	
Pump Type	
Quantity	
Power Supply	
Serial No. / Equip No.	
Notes:	
Product Name:	
Pump Type	
Quantity	
Power Supply	
Serial No. / Equip No.	
Notes:	
Product Name:	
Pump Type	
Quantity	
Power Supply	
Serial No. / Equip No.	
Notes:	
Product Name:	
Pump Type	
Quantity	
Power Supply	
Serial No. / Equip No.	
Notes:	

EASY GUIDE SERVICE AGREEMENT & WORK / EQUIPMENT SCHEDULE

SERVICE AGREEMENT

STEP 1 CLIENT DETAILS

Please complete with the billing names and address.

STEP 2 SERVICE INTERVALS

Using the table please indicate the number of service visits per year. The number of visits should depend on the type and frequency of use. If in doubt please contact our service department on 01442 211554.

STEP 3 SERVICE CHARGE

The service charge is the amount for each service visit.

STEP 4 DURATION OF SERVICE AGREEMENT

Please enter the Agreement Duration in years along with the corresponding Agreement Termination date. Please note that all price reviews are conducted at the end of the term, there if entering into a 5 year term you will not be subject to any price increases until the end of the 5 years.

edincare
PUMPED DRAINAGE SYSTEMS

SERVICE AGREEMENT FOR UNITED KINGDOM INSTALLATIONS

Customer Name (Billing Details) Contract No. (Job No.)
 Name: _____
 Address: _____
 City: _____
 Postcode: _____
 Telephone (Home): _____ Telephone (Work): _____
 Mobile: _____ Fax: _____

Service Intervals

1-2 visits per year	<input type="checkbox"/>
3-4 visits per year	<input type="checkbox"/>
5-6 visits per year	<input type="checkbox"/>
7-8 visits per year	<input type="checkbox"/>
9-10 visits per year	<input type="checkbox"/>

Service Charge

£0 - 100	<input type="checkbox"/>
£100 - 200	<input type="checkbox"/>
£200 - 300	<input type="checkbox"/>
£300 - 400	<input type="checkbox"/>
£400 - 500	<input type="checkbox"/>
£500 - 600	<input type="checkbox"/>
£600 - 700	<input type="checkbox"/>
£700 - 800	<input type="checkbox"/>
£800 - 900	<input type="checkbox"/>
£900 - 1000	<input type="checkbox"/>

Duration of Service Agreement

1 year 2 years 3 years 4 years 5 years

Agreement Termination Date: _____

edincare
PUMPED DRAINAGE SYSTEMS

SERVICE AGREEMENT FOR UNITED KINGDOM INSTALLATIONS

On Behalf of the Client:
 Name: _____
 Position: _____
 Signature: _____

On Behalf of the Company:
 Name: _____
 Position: _____
 Signature: _____

Edincare Pumped Drainage Systems
 Tel: 01442 211554
 Fax: 01442 211555
 Email: info@edincare.com
 Web: www.edincare.com

STEP 5 CLIENT SIGNATURE

Ensure that you have fully read and understood the agreement, only then please sign and date.

WORK / EQUIPMENT SCHEDULE

STEP 6 SITE ADDRESS

If the site details are different from the billing details (Step 1) please complete.

STEP 7 CONTACT DETAILS

Please complete with your contact details.

edincare
PUMPED DRAINAGE SYSTEMS

WORK / EQUIPMENT SCHEDULE

Location of Installation (if different from above): _____

Equipment Schedule

Equipment	Make	Model	Serial No.	Year
1. Main Pump				
2. Backup Pump				
3. Control Panel				
4. Alarm System				
5. Other				

Edincare Pumped Drainage Systems
 Tel: 01442 211554
 Fax: 01442 211555
 Email: info@edincare.com
 Web: www.edincare.com

STEP 8 LOCATION OF INSTALLATION

Please provide details of the installation location along with any site restrictions.

STEP 9 PREFERRED SERVICE MONTH(S)

Please specify your preferred month(s) for your service visit(s). We will endeavour to meet with your selection.

STEP 10 EQUIPMENT SCHEDULE

Please complete the equipment schedule with the products installed (if known).

RETURN TO EDINCARE

STEP 11 RETURN TO EDINCARE

Once you have completed both the 'Service Agreement' and 'Work / Equipment Schedule' please return to us using the prepaid envelope enclosed. The agreement will be counter signed and returned to you for your records.

Should you have any questions please contact our service department on 01442 211554